

# Laser Particle Sensor module

## PM-G3

### Features

- ✧ Principle of laser scattering
- ✧ 100% calibration in factory
- ✧ Constant fan speed control
- ✧ Long life laser
- ✧ Unique algorithm and compensation to get high accuracy
- ✧ Optimized structure and aerodynamic design
- ✧ EMI/EMC
- ✧ Good reliability



### Product Series

Series \ Model	Standard	Common	Slim	Infrared Upgrade	Mini Type	Outdoor	Infrared Type
PM-D4	★						
<b>PM-G3</b>		★					
PM-E5	★	☆					
PM-G7		★	★				
PM-G7M		★	★				
PM-T7	★	☆	★				
PM-T7M	★	☆	★				
PM-R3				★			
PM-H3		★					
PM-S1	☆	★			★		
PM-SP1						★	
PM-A3							★

★: Available in all cases ☆: Available in some cases

Standard Series : Patented product

Common Series : Compatible with other models in the market

Slim Series : Slim design, only 12mm thick

Mini Type Series : Designed for space saving, mini size

Infrared Upgrade : Laser scattering principle, used to upgrade mainstream infrared sensors on the market

Outdoor Series : Specially designed for the harsh outdoor environment

Infrared Type Series : Infrared principle, low cost



## PM-G3

### Specification

Item	Type
Range with good Accuracy (PM2.5 concentration)	0~500 $\mu\text{g}/\text{m}^3$
Maximum measurement range (PM2.5 concentration)	1000 $\mu\text{g}/\text{m}^3$
Resolution(Particle mass concentration)	1 $\mu\text{g}/\text{m}^3$
Minimum particle size	0.3 $\mu\text{m}$
Maximum consistency error (PM2.5 concentration) (25 $\pm$ 5) $^{\circ}\text{C}$ , (50 $\pm$ 10)%RH,	$\pm$ 10%, @ (100~500) $\mu\text{g}/\text{m}^3$ $\pm$ 10 $\mu\text{g}/\text{m}^3$ , @ (0~100) $\mu\text{g}/\text{m}^3$
Response Time	$\leq$ 3s
Data Output	UART@3.3V PWM
I/o electric	(VIH): 1.8V~5V
	(VIL) <0.8V
	(VOH) >2.9V
	(VOL) <0.4V
Power supply	5V (4.8V~5.5V)
Working Current	<100mA
Operation temperature/humidity	(-10~60) $^{\circ}\text{C}$ / (0~99)% RH (non-condensation)
Storage temperature	-30 $^{\circ}\text{C}$ ~70 $^{\circ}\text{C}$
Size	50*42*20mm
MTTF	>30000hrs

#### Note:

Range with good consistency:The measuring range to ensure the nominate consistency .

### I/O Interface Definition

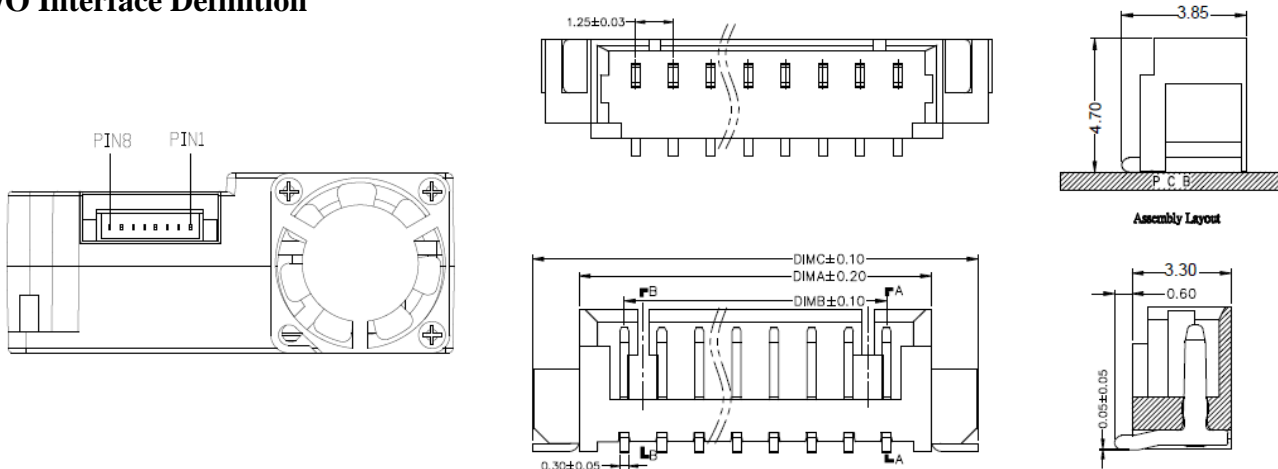

**8PIN Connector**



**PM-G3**

**Pin Description**

PIN No.	Name	PIN Description
PIN1	VCC	Power Supply
PIN2	GND	Ground
PIN3	SLEEP	Sleep:Low level Operating:High level or NC(It should be not-connected if no use)
PIN4	RXD	UART Digital Input
PIN5	TXD	UART Digital Output
PIN6	NC	NC(It should be not-connected)
PIN7	NC	NC(It should be not-connected)
PIN8	PWM	PWM Output (It should be not-connected if no use)

**Dimensions ( Unit : mm )**

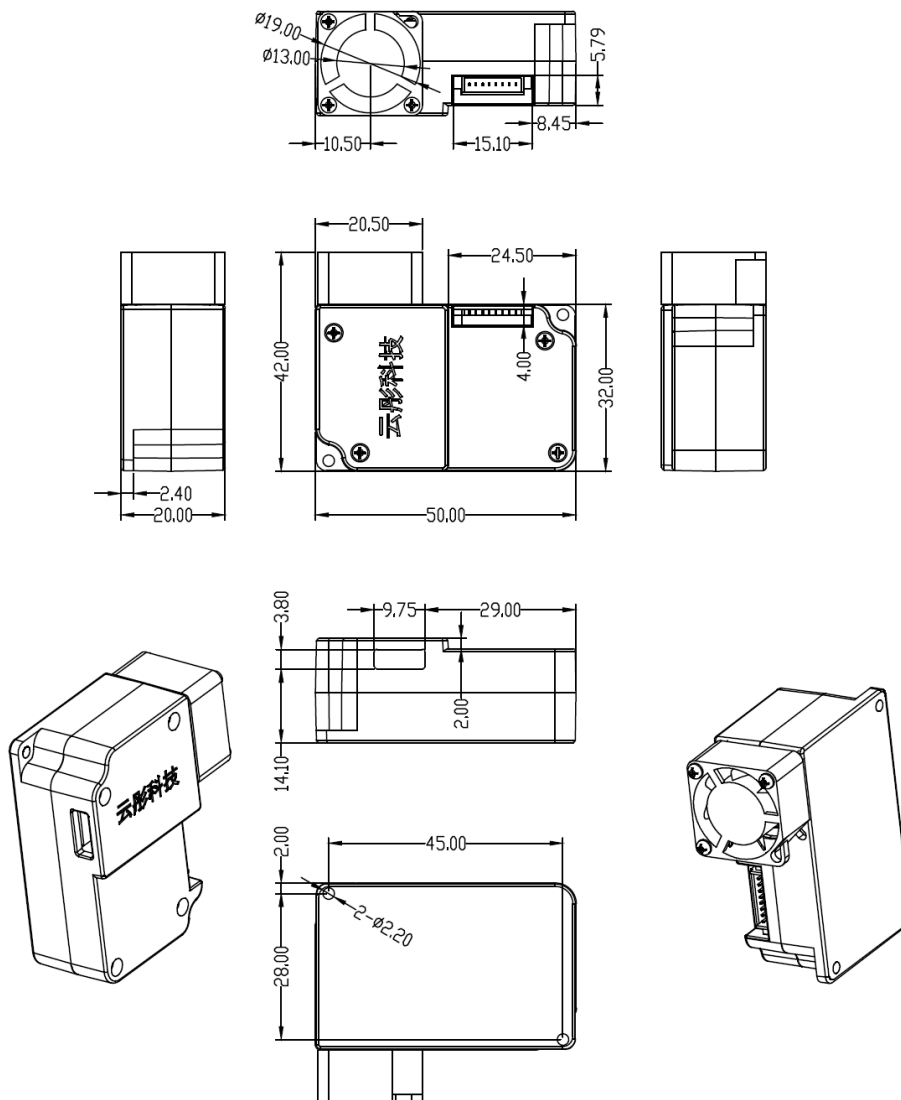



## PM-G3

### Communication Protocol

- **TTL Output (3.3V)**
- **Baud Rate: 9600Kbps ,Check Bit: none ,Stop Bit: 1**
- **32 bytes Data Package**

No. (Hexadecimal)	Data No.	Data	Data Description
0x00	Header 1	0x42	Frame header
0x01	Header 2	0x4d	
0x02	Frame Length high byte	0xXX	Frame Length=2*13+2(Data+Check)
0x03	Frame Length low byte	0xXX	
0x04	Data 1 High byte	0xXX	Concentration of PM 1.0 Unit: $\mu\text{g}/\text{m}^3$
0x05	Data 1 Low byte	0xXX	
0x06	Data 2 High byte	0xXX	Concentration of PM 2.5 Unit: $\mu\text{g}/\text{m}^3$
0x07	Data 2 Low byte	0xXX	
0x08	Data 3 High byte	0xXX	Concentration of PM 10 Unit: $\mu\text{g}/\text{m}^3$
0x09	Data 3 Low byte	0xXX	
0x0A	Data 4 High byte	0xXX	Concentration of PM 1.0 Unit: $\mu\text{g}/\text{m}^3$
0x0B	Data 4 Low byte	0xXX	
0x0C	Data 5 High byte	0xXX	Concentration of PM 2.5 Unit: $\mu\text{g}/\text{m}^3$
0x0D	Data 5 Low byte	0xXX	
0x0E	Data 6 High byte	0xXX	Concentration of PM 10 Unit: $\mu\text{g}/\text{m}^3$
0x0F	Data 6 Low byte	0xXX	
0x10	Data 7 High byte	0xXX	The particle number with diameter above $0.3\mu\text{m}$ in the air per 0.1L
0x11	Data 7 Low byte	0xXX	
0x12	Data 8 High byte	0xXX	The particle number with diameter above $0.5\mu\text{m}$ in the air per 0.1L
0x13	Data 8 Low byte	0xXX	
0x14	Data 9 High byte	0xXX	The particle number with diameter above $1.0\mu\text{m}$ in the air per 0.1L
0x15	Data 9 Low byte	0xXX	
0x16	Data 10 High byte	0xXX	The particle number with diameter above $2.5\mu\text{m}$ in the air per 0.1L
0x17	Data 10 Low byte	0xXX	
0x18	Data 11 High byte	0xXX	The particle number with diameter above $5.0\mu\text{m}$ in the air per 0.1L
0x19	Data 11 Low byte	0xXX	
0x1A	Data 12 High byte	0xXX	The particle number with diameter above $10\mu\text{m}$ in the air per 0.1L
0x1B	Data 12 Low byte	0xXX	
0x1C	Data 13 High byte	0xXX	Reserved(0)
0x1D	Data 13 Low byte	0xXX	
0x1E	Check High byte	0xXX	Check =Start Symbol 1+Start Symbol 2+.....+Data 13 Low byte
0x1F	Check Low byte	0xXX	



## PWM Output

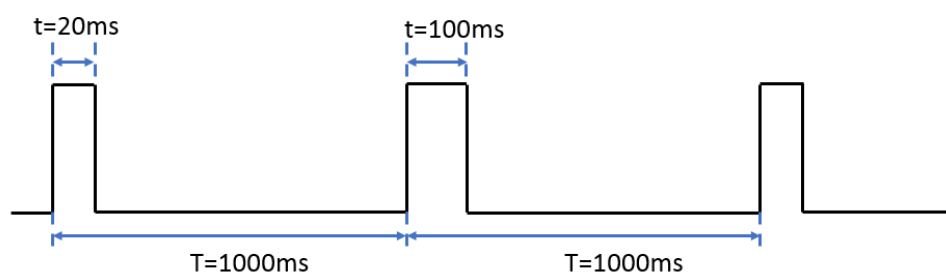

- PWM Pulse Period  $T \approx 1000\text{ms}$
- The measured time on high level is  $t$
- $\text{PM}_{2.5} = t/T * 1000$  ( $\mu\text{g}/\text{m}^3$ )
- In the first cycle,  $t=20\text{ms}$ ,  $T=1000\text{ms}$ ,  $\text{PM}_{2.5}=20 \mu\text{g}/\text{m}^3$
- In the second cycle,  $t=100\text{ms}$ ,  $T=1000\text{ms}$ ,  $\text{PM}_{2.5}=100 \mu\text{g}/\text{m}^3$
- PMW output (PM<sub>2.5</sub>particle mass concentration ) range is  $(0 \sim 999) \mu\text{g} / \text{m}^3$



## Circuit Design

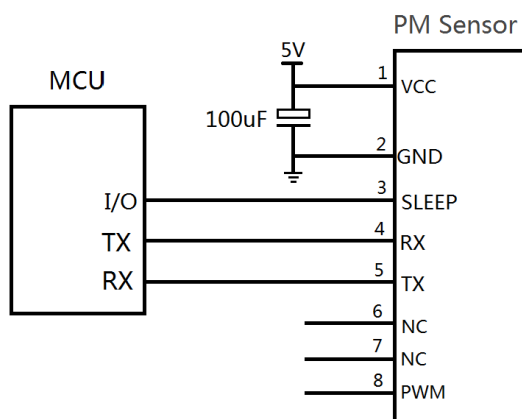

### Note of the circuit design:

1. The sensor is 5V power supply. The sensor has no reverse protection, It cannot be reversed connected. It is recommended to add a 100uF capacitor to the power supply for filtering.
2. Other I/O pins are 3.3V level interfaces.
3. PIN3 is the sleep pin. The low level enable sleep mode. The high level enable the measuring mode. If it's not used ,it is recommended to be not connected.
4. PIN4 is RXD port of the sensor. If it's not used ,it is recommended to be not connected.
5. PIN6 and PIN7 are designed for factory use . If it's not used ,it is recommended to be not connected.
6. PN8 is the PWM output . If it's not used ,it is recommended to be not connected.

## Structural Design

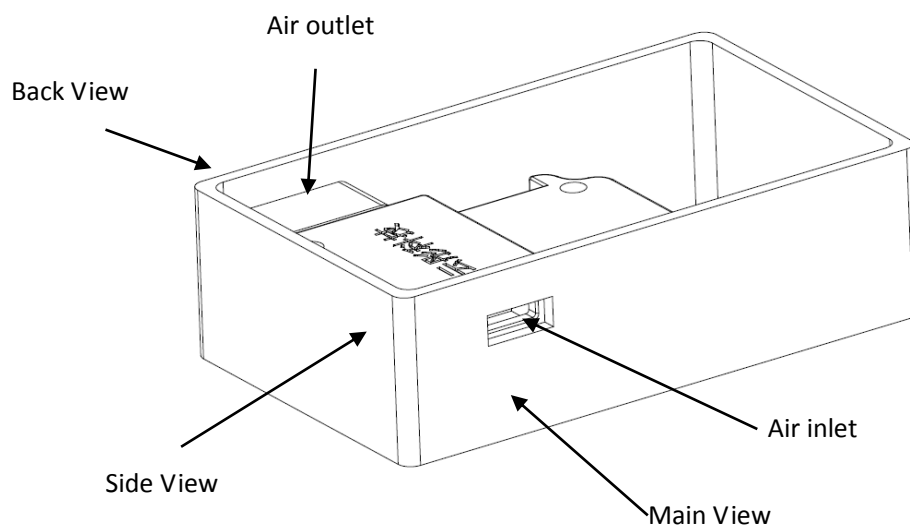

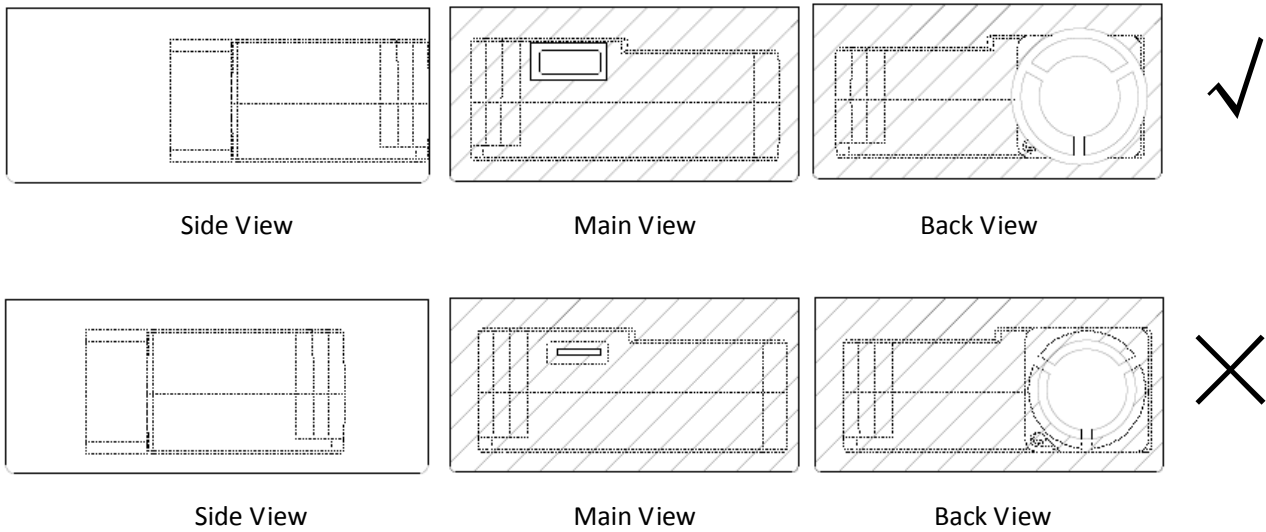

**Note**

1. Mounting and fixed: The sensor recommended use the screw to fixed;
2. Inlet and outlet cannot be intercepted between the measurement environment;
3. Inlet and outlet where the plane must be close to the out wall of the device, and the use of air duct design with the outside, as cannot be achieved, the inlet and outlet should be structured to ensure the airflow in and out isolation;
4. The inlet and outlet of the equipment should be greater than or equal to the size of the sensor inlet and outlet, and ensure that all the inlet are exposed.
5. Equipment designed air duct do not have corners, to ensure the airflow can be measured and go into the sensor ;
6. When the sensor is applied to purifier products, it is necessary to avoid placing the sensor directly in the purifier's own air duct; if it is unavoidable, it is necessary to design a separate structural space to install the sensor to isolate the air inlet and outlet of the sensor from the air duct of the purifier.
7. When applied to purifiers or fixed testing equipment, the working position of the sensor should be higher than 20cm above the ground to prevent the large particles of dust and floccules in that causing the measurement error;
8. Sensor should be away from the higher fever and radiation components;
9. When the sensor is used in outdoor equipment, the protection of large particulate dust, rain and snow, catkins and so on should be completed by the structure of the equipment.



### PM-G3

#### Others

---

1. Due to the electrostatic sensitive components on the module, installation and use of anti-static facility is necessary, such as wearing anti-static gloves;
2. In the process of installation, avoid non-standard operation such as hot swap;
3. Do not disassemble the sensor, or it will lead to irreversible damage;
4. The sensor is designed for indoor air quality measurement. If the equipment is working in the following actual environment, the necessary design should be added to make sure the sensor shows good consistency and long service life,
  - a) the annual dust concentration greater than 300 micrograms per cubic meter for more than 50% of the time, or more than 500 micrograms per cubic meter for more than 20% of the time;
  - b) a fume environment, such as a kitchen;
  - c) high water fog environment, such as bathroom.





### Enclosure 1. Characteristics: Accuracy & Uniformity

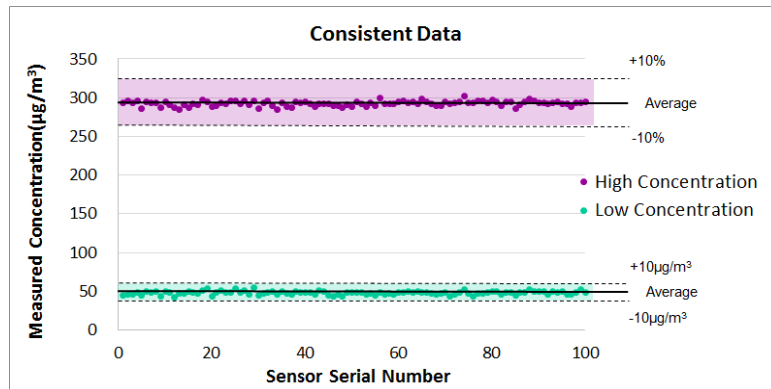

Randomly selected 100pcs sensors in the calibration room, In the high concentration the Uniformity tolerance is within 10%, In the Low concentration the Uniformity tolerance is within 10µg/m<sup>3</sup>

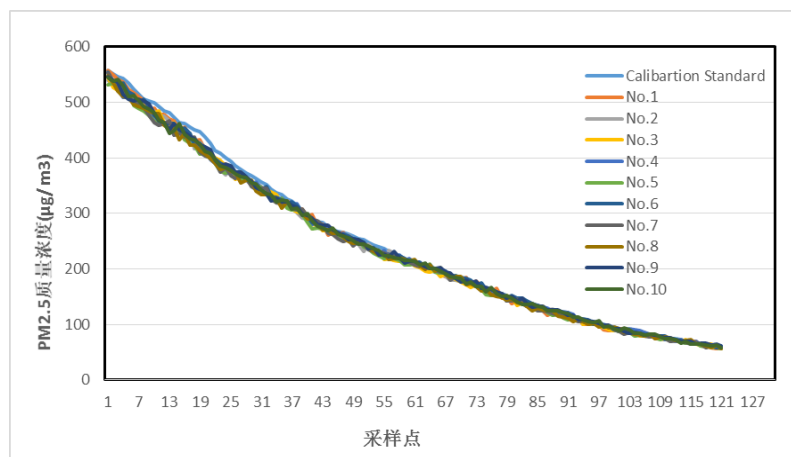

Uniformity (25 degree Celsius & Range of 0 ~ 500µg/m<sup>3</sup>)

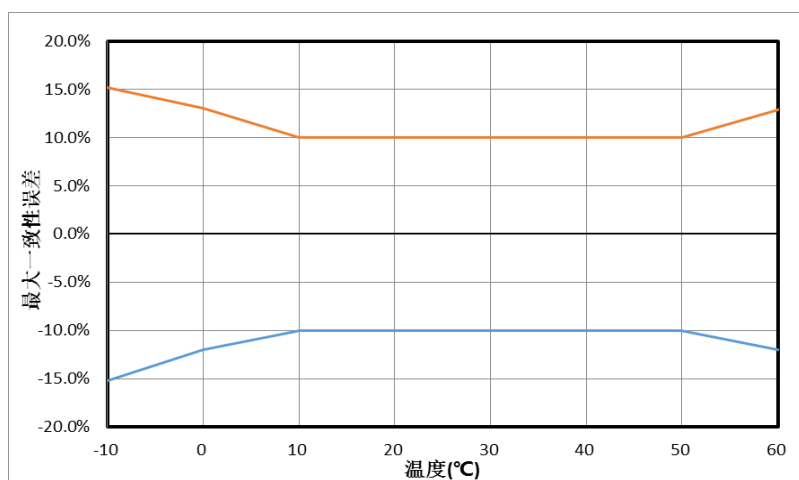

Temperature Characteristics(-10°C~60°C)(Temperature –Uniformity)

**Note:** The characteristic curve according to the test data of the PM-D4



**Enclosure 2. Reliability**

Item	Test Schedule	Acceptance standard
High temperature high humidity storage	Constant temperature chamber, temperature 70 °C, humidity (90 ~ 95)% RH; test duration: 96hours	After working for 2 hours at room temperature. 1. The test condition :temperature of (25 ± 5) °C, humidity (50 ± 10)% RH, Cigarette smoke environment:(0 ~ 100) µg / m <sup>3</sup> range to meet the consistency error of less than ± 10µg / m <sup>3</sup> ;(100 ~ 500) µg / m <sup>3</sup> range, to meet the consistency error of less than ± 10%; 2. Sensor has no abnormal sound and noise; 3. The output value is stable; 4. Normal appearance without distortion.
Low temperature storage	Constant temperature chamber, temperature -30 °C; test duration: 96H	
Work Temperature characteristic	Standard temperature chamber, the temperature changes slowly, from -5 °C ~ 50 °C, every 10 °C constant 20mins, measuring the sensor .(temperature includes and cover the highest and lowest value)	1. The test condition :temperature (25 ± 5) °C, humidity (50 ± 10)% RH, Cigarette smoke environment: (0 ~ 100) µg / m <sup>3</sup> range, to meet the consistency error less than ± 15µg / m <sup>3</sup> ; (100 ~ 500) µg / m <sup>3</sup> range to meet the consistency error of less than ± 15%; 2. Sensor has no abnormal sound and noise; 3. The output value is stable; 4. Normal appearance without distortion.
Long term performance	Temperature (25 ± 5) °C, humidity (20 ~ 70)% RH, running time 1000hours	
Vibration test	1.30 m <sup>3</sup> temperature room, temperature (25 ± 5) °C, humidity (50 ± 10)% RH; 2. Vibration frequency 50Hz, amplitude 2mm, X \ Y \ Z direction test 1H	
Power fluctuations	1.30 m <sup>3</sup> temperature room, temperature (25 ± 5) °C, humidity (50 ± 10)% RH; 2. Adjust the power supply, 4.5V-5V-4.5V, voltage gradient of 0.1V / min, 500 rounds	
High temperature operation	Constant temperature chamber, temperature 60 °C, test time: 360h	
Low temperature operation	Constant temperature chamber, temperature -10 °C; Test time: 360h	After working for 2 hours at room temperature. 1. The test condition :temperature (25 ± 5) °C, humidity (50 ± 10)% RH, Cigarette smoke environment: (0 ~ 100) µg / m <sup>3</sup> range, to meet the consistency error less than ± 15µg / m <sup>3</sup> ; (100 ~ 500) µg / m <sup>3</sup> range to meet the consistency error of less than ± 15%; 2. Sensor has no abnormal sound and noise; 3. The output value is stable; 4. Normal appearance without distortion.
Power switch test	DC 5V power supply, switching frequency 0.5Hz, duration of 100 hours (6000 rounds)	
Sleep PIN switch test	DC 5V power supply, Sleep level switch frequency 0.5Hz, duration of 100 hours (6000 rounds)	
Salt flog test	Concentration of 5% industrial brine, hydrolytic spray 48h, remove with the pure water, place 48h	Wash and remove with the pure water, put 48h .metal parts without rust and discoloration



## PM-G3

### Packing

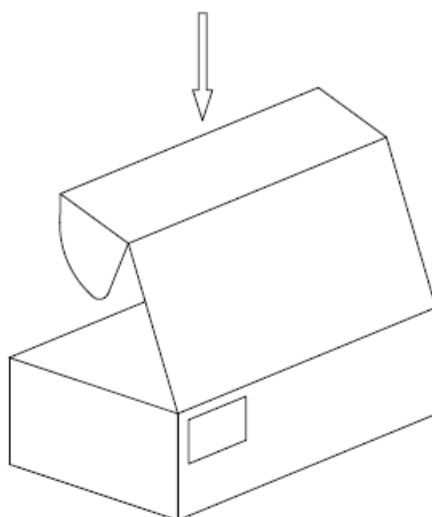
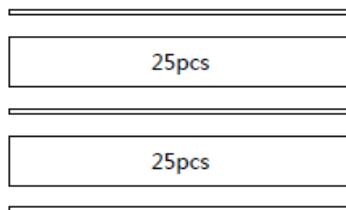
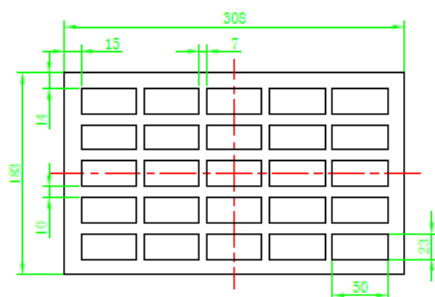

Qty. per layer	Layer	Carton	Carton dimensions	Packing material
25pcs	2 Layers	50pcs	310*184*105	Pearl cotton(ESD)

### Technical consultancy and After-sales services

Hippocampus Technology Co.,Ltd

Tel: +86 0519-85552750

Address: Building No.15 Innovative Industrial Park ,No.377 Wuyi road(south),Wuijin District ,Changzhou City

Web: [www.topsensor.cn](http://www.topsensor.cn)